

Damping rings type DT and DT.../2

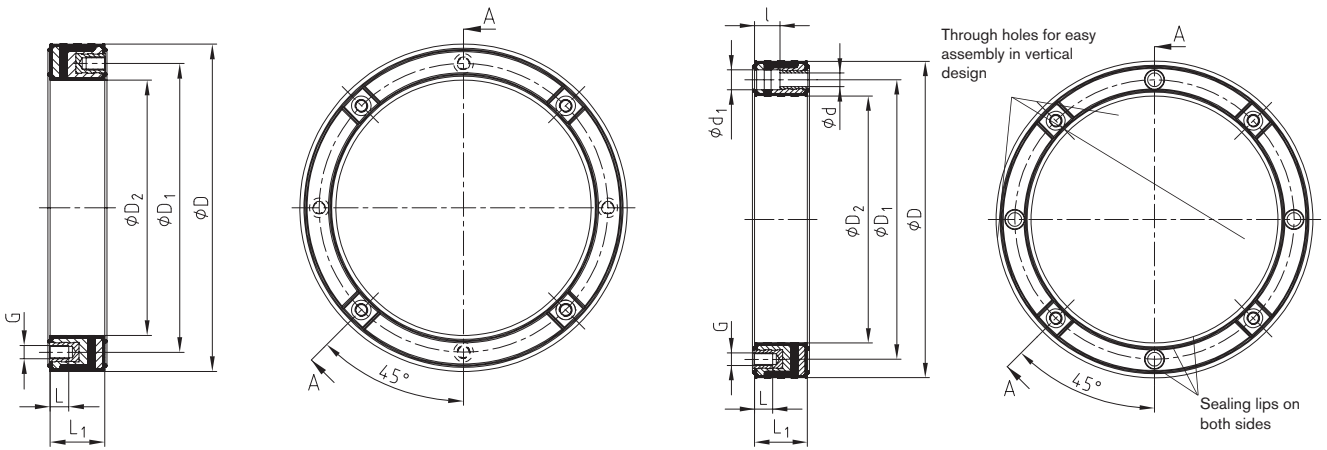

Damping ring type DT

Damping ring type DT.../2



Damping ring type DT (patent pending) and DTV

IEC motor size	Damping ring size	Dimensions [mm]									Screw tightening torque [Nm]
		D	D ₁	D ₂	z x G	L	L ₁	z x d	z x d ₁	l	
71	DTV 160	160	130	111	4 x M8	16,5	35	4 x 9	4 x 14,5	18	12
80, 90S / 90L	DT 200	200	165	145,2	4 x M10	20	40	4 x 11	4 x 17,5	20	23
100L / 112M	DT 250	250	215	191	4 x M12	17,5	45	4 x 13	4 x 19,5	22	40
132S / 132M	DT 300	300	265	235	4 x M12	17,5	50	4 x 13	4 x 19	24	40
160M / 160L, 180M / 180L	DT 350	350	300	261	4 x M16	31	60	4 x 17	4 x 25	26	100
200L	DT 400	400	350	301	4 x M16	31	70	4 x 17	4 x 25	31	100
225S / 225M	DT 450	450	400	351	8 x M16	31	80	8 x 17	8 x 25	41	100
250M, 280S / 280M	DT 550	550	500	451	8 x M16	30	68	8 x 17	8 x 25	23	210
315S / 315M	DT 660	660	600	551	8 x M20	30	68	8 x 22	8 x 33	23	410
355	DTV 800	800	740	681	8 x M20	25	71	-	-	-	410

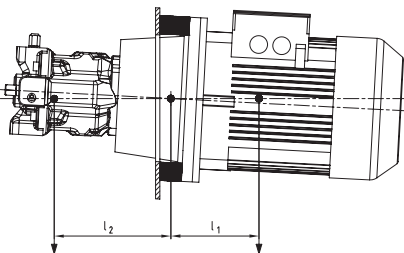

Permissible radial weight and bending load of damping rings type DT based on an operating temperature of + 60 °C

DT size	200	250	300	350	400	450	550	660
F _{perm.} [N]	370	720	1450	3600	4800	6600	13000	24000
M _{b perm.} [Nm]	30	65	175	740	1100	1600	4400	9000

$$F_{perm.} \geq F_P + F_M$$

$$M_{b perm.} \geq F_M \cdot l_1 - F_P \cdot l_2$$

Ordering example:

DT	250
Damping ring	Size